

EN

# Consolidated TEXT

produced by the **CONSLEG** system

of the Office for Official Publications of the European Communities

---

CONSLEG: 1974L0060 — 08/04/2000

*Number of pages: 34*

---



Office for Official Publications of the European Communities

This document is meant purely as documentation tool and the institutions do not assume any liability for its contents

► **B**

► **M2** COUNCIL DIRECTIVE

of 17 December 1973

on the approximation of the laws of the Member States relating to the interior fittings of motor vehicles

(74/60/EEC) ◀

(OJ L 38, 11.2.1974, p. 2)

Amended by:

		Official Journal		
		No	page	date
► <b><u>M1</u></b>	Commission Directive 78/632/EEC of 19 May 1978	L 206	26	29.7.1978
► <b><u>M2</u></b>	Directive 2000/4/EC of the European Parliament and of the Council of 28 February 2000	L 87	22	8.4.2000

Corrected by:

► **C1** Corrigendum, OJ L 215, 6.8.1974, p. 20 (74/60/EEC)

► **C2** Corrigendum, OJ L 53, 25.2.1977, p. 30 (74/60/EEC)

▼B  
▼M2

## COUNCIL DIRECTIVE

of 17 December 1973

**on the approximation of the laws of the Member States relating to the interior fittings of motor vehicles**

(74/60/EEC)

▼B

THE COUNCIL OF THE EUROPEAN COMMUNITIES,

Having regard to the Treaty establishing the European Economic Community, and in particular Article 100 thereof;

Having regard to the proposal from the Commission;

Having regard to the Opinion of the European Parliament <sup>(1)</sup>;

Having regard to the Opinion of the Economic and Social Committee <sup>(2)</sup>;

Whereas the technical requirements which motor vehicles must satisfy pursuant to national laws relate, *inter alia*, to interior fittings for the protection of the occupants;

Whereas these requirements differ from one Member State to another; whereas it is therefore necessary that all Member States adopt the same requirements either in addition to or in place of their existing regulations in order, in particular, to allow for the EEC type approval procedure, which was the subject of the Council Directive of 6 February 1970 <sup>(3)</sup> on the approximation of the laws of the Member States relating to the type approval of motor vehicles and their trailers to be applied in respect of each type of vehicle;

Whereas common requirements for interior rear view mirrors have been laid down by the Council Directive of 1 March 1971 <sup>(4)</sup> and requirements should also be drawn up for the interior fittings of the passenger compartment, the layout of the controls, the roof and backrest and rear part of the seats; whereas other requirements will be adopted subsequently on interior fittings and relating to the anchorages for safety belts and seats, head restraints, the protection of the driver against the steering unit and the layout of the controls;

Whereas harmonized requirements must reduce the risk or the severity of injuries of which motor vehicle drivers may be victims and thereby ensure road safety throughout the entire Community;

Whereas, with regard to technical requirements, it is appropriate to utilize basically those adopted by the United Nations Economic Commission for Europe in its Regulation No 21 ('Uniform requirements concerning the approval of vehicles with regard to their interior fittings') which is annexed to the Agreement of 20 March 1958 concerning the adoption of uniform conditions of approval and reciprocal recognition of approval for motor vehicle equipment and parts,

HAS ADOPTED THIS DIRECTIVE:

▼M2

### Article 1

For the purpose of this Directive, 'vehicle' means any vehicle as defined in Article 2 of Directive 70/156/EEC.

<sup>(1)</sup> OJ No C 112, 27. 10. 1972, p. 14.

<sup>(2)</sup> OJ No C 123, 27. 11. 1972, p. 32.

<sup>(3)</sup> OJ No L 42, 23. 2. 1970, p. 1.

<sup>(4)</sup> OJ No L 68, 22. 3. 1971, p. 1.

**▼M2***Article 2*

No Member State may refuse to grant EC type-approval or national type-approval of a vehicle on grounds relating to the interior fittings of the vehicles if these meet the requirements set out in the Annexes hereto.

*Article 3*

No Member State may refuse to register or prohibit the sale, entry into service or use of any vehicle on grounds relating to the interior fittings of the vehicles if these meet the requirements set out in the Annexes.

---

**▼B***Article 6*

1. Member States shall put into force provisions necessary in order to comply with this Directive within eighteen months of its notification and shall immediately inform the Commission thereof.
2. Member States shall ensure that the texts of the main provisions of national law which they adopt in the field covered by this Directive are communicated to the Commission.

*Article 7*

This Directive is addressed to the Member States.

**▼M2***LIST OF ANNEXES*

- ANNEX I: Scope, definitions, application for EC type-approval of a vehicle type, specifications, granting of EC type-approval of a vehicle type, modifications of the type and amendments to approvals and conformity of production
- Appendix 1: Information document
- Appendix 2: EC type-approval certificate
- Appendix 3: Position of cylindrical test rod in the opening roof and window openings
- Appendix 4: Symbol for driver controlled switch
- ANNEX II: Determination of the head-impact zone
- ANNEX III: Procedure for testing energy-dissipating materials
- ANNEX IV: Procedure for determining the H point and the actual seat-back angle and for verifying the relative positions of the R and H points and the relationship between the design seat-back angle and the actual seat-back angle
- Appendix: Components of three-dimensional manikin and dimensions and mass of manikin
- ANNEX V: Method of measuring projections
- Appendix: Apparatus for measuring projections
- ANNEX VI: Apparatus and procedure for application of Item 5.2.1 of Annex I

**▼B**ANNEX I ► **M2** ←**▼M2****SCOPE, DEFINITIONS, APPLICATION FOR EC TYPE-APPROVAL OF A VEHICLE TYPE, SPECIFICATIONS, GRANTING OF EC TYPE-APPROVAL OF A VEHICLE TYPE, MODIFICATIONS OF THE TYPE AND AMENDMENTS TO APPROVALS AND CONFORMITY OF PRODUCTION**

## 1. SCOPE

This Directive applies to vehicles of category M<sub>1</sub> as defined in Annex II, Section A to Directive 70/156/EEC.

**▼B**

## 2. DEFINITIONS

For the purposes of this Directive

**▼M2**

## 2.1. 'Interior fittings' are:

2.1.1. interior parts of the passenger compartment other than the interior rear-view mirrors,

2.1.2. the layout of the controls,

2.1.3. the roof or opening roof,

2.1.4. the backrest and the rear part of the seats,

2.1.5. power-operated windows, roof panel and partition systems,

2.2. 'vehicle type' with respect to the interior fittings of a passenger compartment means motor vehicles which do not differ in such essential respects as:

**▼B**

2.2.1. the lines of constituent materials of the bodywork of the passenger compartment,

2.2.2. the arrangement of the controls,

**▼M2**

2.2.3. the roof or opening roof,

2.2.4. the backrest and the rear part of the seats,

2.2.5. power-operated windows, roof panel and partition systems,

**▼B**

2.3. 'reference zone' means the head impact zone as defined in Annex II except:

2.3.1. the area bounded by the forward horizontal projection of a circle circumscribing the outer limits of the steering control, increased by a peripheral band 127 mm in width; this area is bounded below by the horizontal plane tangential to the lower edge of the steering control when the latter is in the position for driving straight ahead,

2.3.2. the part of the surface of the instrument panel comprised between the edge of the area specified in point 2.3.1 above and the nearest inner side-wall of the vehicle; this surface is bounded below by the horizontal plane tangential to the lower edge of the steering control; and

2.3.3. the windscreen side pillars,

2.4. 'level of the instrument panel' shall mean the line defined by the points of contact of vertical tangents to the instrument panel,

2.5. 'roof' shall mean the upper part of the vehicle extending from the upper edge of the windscreen to the upper edge of the rear window, bounded at the sides by the upper framework of the side-walls,

**▼B**

- 2.6. ►**M1** 'belt line' shall mean the line formed by the transparent lower contour of the side windows of the vehicle ◀,
- 2.7. ►**M1** 'convertible vehicle' shall mean a vehicle where in certain configurations there is no rigid part of the vehicle body above the belt line with exception of the front roof supports and/or the roll-over bars and/or the seat-belt anchorage points ◀,
- 2.8. ►**M1** 'vehicle with opening roof' shall mean a vehicle of which only the roof or a part of it can be folded back or be open, or may slide, leaving the existing structural elements of the vehicle above the belt line ◀,

**▼M1**

- 2.9. 'folding (tip-up) seat' shall mean an auxiliary seat intended for occasional use and which is normally folded out of the way,

**▼M2**

- 2.10. 'power-operated windows' means windows which are closed by power supply of the vehicle,
- 2.11. 'power-operated roof-panel systems' means movable panels in the vehicle roof which are closed by power supply of the vehicle by either a sliding or tilting motion, and which do not include convertible top systems,
- 2.12. 'power-operated partition systems' means systems which divide a passenger car compartment into at least two sections and which are closed using the power supply of the vehicle,
- 2.13. 'opening' is the maximum unobstructed aperture between the upper edge or the leading edge, depending on the closing direction, of a power-operated window or partition or roof panel and the vehicle structure which forms the boundary of the window, partition or roof panel, when viewed from the interior of the vehicle or, in the case of partition system, from the rear part of the passenger compartment.
- To measure an opening, a cylindrical test rod shall (without exerting force) be placed through it normally perpendicular to the window, roof panel or partition as shown in Figure 1, from the interior of the vehicle or, as applicable, from the rear part of passenger compartment.

3. APPLICATION FOR EC TYPE-APPROVAL OF A VEHICLE TYPE

- 3.1. The application for EC type-approval pursuant to Article 3(4) of Directive 70/156/EEC of a vehicle type with regard to its interior fittings shall be submitted by the manufacturer.
- 3.2. A model of the information document is given in Appendix 1.
- 3.3. The following must be submitted to the technical service responsible for conducting the type-approval tests:

**▼B**

- 3.3.1. at the manufacturer's discretion, either a vehicle representative of the vehicle type to be approved or the part(s) of the vehicle regarded as essential for the checks and tests prescribed by this Directive; and
- 3.3.2. at the request of the aforesaid technical service, certain components and certain samples of the materials used.

(4.)

5. SPECIFICATIONS

- 5.1. **Forward interior parts of the passenger compartment above the level of the instrument panel in front of the front seat H points, excluding the side doors**

- 5.1.1. The reference zone defined in point 2.3 above must not contain any dangerous roughness or sharp edges likely to increase the risk of serious injury to the occupants. Those parts referred to in

## ▼B

- points 5.1.2 to 5.1.6 hereafter shall be deemed satisfactory if they comply with the requirements thereof.
- 5.1.2. Vehicle parts within the reference zone with the exception of those which are not part of the instrument panel and which are placed at less than 10 cm from glazed surfaces shall be energy-dissipating as prescribed in Annex III. Those parts within the reference zone which satisfy both of the following conditions shall also be excluded from consideration:
- if, during a test in accordance with the requirements of Annex III, the pendulum makes contact with parts outside the reference zone; and
  - if the parts to be tested are placed less than 10 cm away from the parts contacted outside the reference zone, this distance being measured on the surface of the reference zone;
- any metal support fittings shall have no protruding edges.
- 5.1.3. The lower edge of the instrument panel, unless it meets the requirements of point 5.1.2 above, shall be rounded to a radius of curvature of not less than 19 mm.
- 5.1.4. Switches, pull-knobs, etc, made of rigid material, which, measured in accordance with the method described in Annex V from 3.2 mm to 9.5 mm from the panel, shall have a cross-sectional area of not less than 2 cm<sup>2</sup>, measured 2.5 mm from the point projecting furthest, and shall have rounded edges with a radius of curvature of not less than 2.5 mm.
- 5.1.5. If these components project by more than 9.5 mm from the surface of the instrument panel, they shall be so designed and constructed as to be able, under the effect of a longitudinal horizontal force of 37.8 daN delivered by a flat ended ram of not more than 50 mm diameter either to retract into the surface of the panel until they do not project by more than 9.5 mm or to become detached; in the latter case no dangerous projections of more than 9.5 mm shall remain; a cross-section not more than 6.5 mm from the point of maximum projection shall be not less than 6.50 cm<sup>2</sup> in area.
- 5.1.6. In the case of a projection consisting of a component made of non-rigid material of less than 50 shore A hardness mounted on a rigid support, the requirements of points 5.1.4 and 5.1.5 shall apply only to the rigid support.
- 5.2. **Forward interior parts of the passenger compartment below the level of the instrument panel and in front of the front seat H points, excluding the side doors and the pedals**
- 5.2.1. Except for the pedals and their fixtures and those components that cannot be contacted by the device described in Annex VI and used in accordance with the procedure described therein, components covered by point 5.2 shall comply with the requirements of points 5.1.4 to 5.1.6 above.
- 5.2.2. The hand-brake control, if mounted on or under the instrument panel, shall be so placed that, when it is released, there is no possibility of occupants of the vehicle's contacting it in the event of a frontal impact. If this condition is not met, the surface area of the control shall satisfy the requirements of point 5.3.2.3 below.
- 5.2.3. Shelves and other similar items shall be so designed and constructed that their supports in no case have protruding edges and they meet one or other of the following conditions:
- 5.2.3.1. the part facing into the vehicle shall present a surface not less than 25 mm high with edges rounded to a radius of curvature of not less than 3.2 mm. This surface shall ►C2 be covered with or constituted of an energy-dissipating material ◄ as defined in Annex III, and shall be tested in accordance therewith, the impact being applied in a horizontal longitudinal direction.
- 5.2.3.2. Shelves and other similar items shall, under the effect of a forward-acting horizontal longitudinal force of 37.8 daN exerted by a cylinder of 110 mm diameter with its axis vertical, become detached, break up, be substantially distorted or retract without producing dangerous features on the rim of the shelf. The force

▼**B**

must be directed at the strongest part of the shelves or other similar items.

5.2.4. If the items in question contain a part made of material softer than 50 shore A hardness when fitted to a rigid support, the above requirements, except for the requirements covered by Annex III relating to energy absorption, shall apply.

5.3. ►**M1** **Other interior fittings in the passenger compartment in front of the transverse plane passing through the torso reference line of the manikin placed on the rearmost seats** ◀

5.3.1. *Scope*

►**M1** The requirements of point 5.3.2 below shall apply to control handles, levers and knobs and to any other protruding objects not referred to in points 5.1 and 5.2 above (see also under 5.3.2.2). ◀

5.3.2. *Requirements*

►**M1** If the items referred to in point 5.3.1 are so placed that occupants of the vehicle can contact them, they shall meet the requirements of points 5.3.2.1 to 5.3.4. If they can be contacted by a 165 mm diameter sphere and are above the lowest H point (see Annex IV) of the front seats and forward of the transverse plane of the torso reference line of the manikin on the rearmost seat, and outside the zones defined in points 2.3.1 and 2.3.2, these requirements shall be considered to have been fulfilled if: ◀

5.3.2.1. Their surface shall terminate in rounded edges, the radii of curvature being not less than 3·2 mm.

5.3.2.2. Control levers and knobs shall be so designed and constructed that, under the effect of a forward-acting longitudinal horizontal force of 37·8 daN either the projection in its most unfavourable position shall be reduced to not more than 25 mm from the surface of the panel or the said fittings shall become detached or bent: in the two latter cases no dangerous projections shall remain.

Window winders may, however, project 35 mm from the surface of the panel.

5.3.2.3. The hand brake control when in the released position and the gear lever when in any forward gear position, except when placed in the zones defined in points 2.3.1 and 2.3.2 and zones below the horizontal plane passing through the H point of the front seats, shall have a surface area of at least 6·5 cm<sup>2</sup> measured at a cross-section normal to the longitudinal horizontal direction up to a distance of 6·5 mm from the furthest projecting part, the radius of curvature being not less than 3·2 mm.

5.3.3. ►**M1** The requirements of point 5.3.2.3 shall not apply to floor-mounted hand brake control; for such controls if the height of any part in the released position is above a horizontal plane passing through the lowest H point of the front seats (see Annex IV) the control shall have a cross sectional area of at least 6·5 cm<sup>2</sup>, measured in a horizontal plane, not more than 6·5 mm from the furthest projecting part (measured in the vertical direction). The radius of curvature must not be less than 3·2 mm. ◀

5.3.4. Other items of equipment in the vehicle not covered by the preceding points such as seat slide rails, equipment for regulating the horizontal or vertical part of the seat, devices for retracting safety belts, etc. shall not be subject to any of these provisions if they are situated below a horizontal plane passing through the H point of each seat, even though the occupant is likely to come into contact with such items.

▼**M1**

5.3.4.1. Components mounted on the roof but which are not part of the roof structure, such as grab handles, lights and sun visors, etc., shall have a radius of curvature of not less than 3·2 mm and, in addition, the width of the projecting parts shall not be less than the amount of their downward projection; alternatively, these

**▼M1**

components shall pass the energy-dissipation test in accordance with the requirements of Annex III.

**▼B**

5.3.5. If the items in question include a part made of material softer than 50 shore A hardness mounted on a rigid support, the above requirements shall apply only to the rigid support.

5.4. **Roof**5.4.1. *Scope*

5.4.1.1. The requirements of point 5.4.2 below shall apply to the inner face of the roof.

5.4.1.2. However, they shall not apply to such parts of the roof as cannot be contacted by a sphere 165 mm in diameter.

5.4.2. *Requirements*

5.4.2.1. ►**M1** That part of the inner face of the roof which is situated above or forward of the occupants shall exhibit no dangerous roughness or sharp edges, directed rearwards or downwards. The width of the projecting parts shall not be less than the amount of their downward projection and the edges shall have a radius of curvature of not less than 5 mm. In particular, the rigid roof sticks or ribs, with the exception of the header rail of the glazed surfaces and door frames, shall not project downwards more than 19 mm. ◀

5.4.2.2. ►**M1** If the roof sticks or ribs do not meet the requirements of point 5.4.2.1, they must pass the energy-dissipation test in accordance with the requirements of Annex III. ◀

**▼M1**

5.4.2.3. The metal wires which stretch the lining of the roof and the frames of the sun visors must have a maximum diameter of 5 mm or be able to absorb the energy, as prescribed in Annex III. Nonrigid attachment elements of the frames of the sun visors shall meet the requirements of point 5.3.4.1.

**▼B**5.5. ►**M1** **Vehicles with an opening roof** ◀5.5.1. *Requirements*

5.5.1.1. ►**M1** The following requirements and those of point 5.4 above shall apply to vehicles with an opening roof when the roof is in the closed position. ◀

5.5.1.2. In addition, the opening and operating devices shall:  
be so designed and constructed as to exclude as far as possible accidental operation;

5.5.1.2.2. ►**M1** their surfaces shall terminate in rounded edges, the radii of curvature being not less than 5 mm ◀;

5.5.1.2.3. be accommodated, when in the position of rest, in areas which cannot be contacted by a sphere 165 mm in diameter. If this condition cannot be met, the opening and operating devices shall, in the position of rest, either remain retracted or be so designed and constructed that, under the effect of a force of 37·8 daN applied in the direction of impact defined in Annex III as the tangent to the trajectory of the headform, either the projection as described in Annex V shall be reduced to not more than 25 mm beyond the surface on which the devices are mounted or the devices shall become detached; in the latter case no dangerous projections shall remain.

**▼M2**

5.5.2. *Power-operated roof-panel systems*

**▼M2**

- 5.5.2.1. In addition, power-operated roof-panel systems and their controls shall meet the requirements of Item 5.8 below.

**▼B**

- 5.6. **►M1 Convertible vehicles ◀**
- 5.6.1. **►M1** In the case of convertible vehicles, only the underside of the top of the roll-bar and the top of the windscreen frame in all its normal utilization positions shall comply with the requirements of point 5.4. The system of folding rods or links used to support a non-rigid roof shall, where they are situated above or forward of the occupants, exhibit no dangerous roughness or sharp edges, directed rearwards or downwards. ◀

**▼M1**

---

**▼B**

- 5.7. **►M1 Rear parts of seats anchored to the vehicle ◀**
- 5.7.1. *Requirements*
- 5.7.1.1. The surface of the rear parts of seats shall exhibit no dangerous roughness or sharp edges likely to increase the risk or severity of injury to the occupants.
- 5.7.1.2. Except as provided in points 5.7.1.2.1., 5.7.1.2.2, and 5.7.1.2.3, that part of the back of the front seat which is in the head-impact zone, defined in Annex II, shall be energy-dissipating, as prescribed in Annex III. For determining the head-impact zone, the front seats shall, if they are adjustable, be in the rearmost driving position with their backs inclined as near as possible to 25° unless indicated otherwise by the manufacturer.
- 5.7.1.2.1. In the case of separate front seats, the rear passengers' head-impact zone shall extend for 10 cm on either side of the seat centre-line, in the top part of the rear of the seat-back.
- 5.7.1.2.1.bis<sup>(1)</sup> In the case of seats fitted with head-restraints each test shall be carried out with the head-restraint in the lowest position and at a point situated on the vertical line passing through the centre of the head-restraint.
- 5.7.1.2.1.ter<sup>(1)</sup> In the case of a seat which is designed to be fitted in several types of vehicle, the impact zone shall be determined by the vehicle whose rearmost driving position is, of each of the types considered, the least favourable; the resultant impact zone will be deemed adequate for the other types.
- 5.7.1.2.2. In the case of front bench seats, the impact zone shall extend between the longitudinal vertical planes 10 cm outboard of the centre line of each designated outboard seating position. The centre line of each outboard seating position of a bench seat shall be specified by the manufacturer.
- 5.7.1.2.3. **►M1** In the head impact zone outside the limits prescribed in points 5.7.1.2.1 to 5.7.1.2.2 inclusive, the seat frame structure shall be padded to avoid direct contact of the head with it: and, in these zones, shall have a radius of curvature of at least 5 mm. These parts may alternatively satisfy the energy dissipating requirements specified in Annex III. ◀
- 5.7.2. **►M1** These requirements shall not apply to the rearmost seats, to seats facing sideways or rearwards, to back-to-back seats or to folding (tip-up) seats. If the impact zones of the seats, head-restraints and their supports contain parts covered with material softer than 50 Shore A hardness, the above requirements, with the exception of those relating to energy dissipation described in Annex III, shall apply only to the rigid parts. ◀

<sup>(1)</sup> These points are not included in Regulation No 21.

▼M2

- 5.8. **Power-operated windows, roof-panel systems and partition systems**
- 5.8.1. The requirements below apply to power-operated windows/roof-panel systems/partition systems to minimise the possibility of injuries caused by accidental or improper operation.
- 5.8.2. *Normal operating requirements*
- Except as provided in Item 5.8.3, power-operated windows/roof-panel systems/partition systems may be closed under one or more of the following conditions:
- 5.8.2.1. when the ignition key is inserted in the ignition control in any position of use;
- 5.8.2.2. by muscular force unassisted by power supply of the vehicle;
- 5.8.2.3. on continuous activation by a locking system on the outside of the vehicle;
- 5.8.2.4. during the interval of time between the moment the ignition has been switched from 'on' to 'off' and/or the key has been removed and the moment that neither of the two front doors has been opened sufficiently to permit egress of occupants;
- 5.8.2.5. when the closing movement of a power-operated window, roof panel or partition starts at an opening not exceeding 4 mm;
- 5.8.2.6. when the power-operated window of a vehicle's door without an upper door frame closes automatically whenever the pertinent door is closed. In this case the maximum opening, as defined in Item 2.13, prior to window closing, shall not exceed 12 mm.
- 5.8.2.7. Remote closing shall be allowed by continuous activation of a remote actuation device, provided one of the following conditions is fulfilled:
- 5.8.2.7.1. the remote actuation device shall be incapable of closing the power-operated window/roof panel/partition from a distance of more than 11 metres from the vehicle;
- 5.8.2.7.2. the remote actuation device shall be incapable of closing the power-operated window/roof panel/partition:
- if the actuation device and the vehicle are separated by an opaque surface
  - and
  - if from the distance between the remote actuation device and the vehicle is more than 6 metres.
- 5.8.2.8. One-touch closing shall be permitted only for the power-operated window of the driver's door and the roof panel, and only during the time when the ignition key is in the engine running position.
- 5.8.3. *Auto-reversing requirements*
- 5.8.3.1. None of the requirements in Item 5.8.2 shall apply if a power-operated window/roof panel system/partition is fitted with an auto-reversing device.
- 5.8.3.1.1. This device shall reverse the window/roof panel/partition before it exerts a pinch force of more than 100 N within the opening of 200 mm to 4 mm above the top edge of a power-operated window/partition or in front of the leading edge of a sliding roof panel and at the trailing edge of a tilting roof panel.
- 5.8.3.1.2. After such an auto-reversal, the window or roof panel or partition shall open to one of the following positions:
- 5.8.3.1.2.1. a position that permits a semi-rigid cylindrical rod of a diameter of 200 mm to be placed through the opening at the same contact point(s) used to determine the reversing behaviour in Item 5.8.3.1.1;

## ▼M2

- 5.8.3.1.2.2. a position that represents at least the initial position before closing was initiated;
- 5.8.3.1.2.3. a position at least 50 mm more open than the position at the time when reversing was initiated;
- 5.8.3.1.2.4. in the case of tilting motion of a roof panel, the maximum angular opening.
- 5.8.3.1.3. To check power-operated windows/roof-panel systems/partition systems with reversing devices, a measuring instrument/test rod shall be placed through the opening from the inside of the vehicle or, in the case of a partition system, from the rear part of the passenger compartment in such a way that the cylindrical surface of the rod contacts any part of the vehicle structure which forms the boundary of the window/roof-panel aperture/partition. The force deflection ratio of the measuring instrument shall be not more than 10 N/mm. The position of the test rods (normally located perpendicular to the window/roof panel/partition) are illustrated in Appendix 3, Figure 1.
- 5.8.4. *Switch location and operation*
- 5.8.4.1. Switches of power-operated windows/roof panels/partitions shall be located or operated in such a way to minimise the risk of accidental closing. The switches shall require continuous actuation for closing except in the case of Items 5.8.2.6, 5.8.2.8 or 5.8.3.
- 5.8.4.2. All rear-window, roof-panel and partition switches intended for use by occupants in the rear of the vehicle shall be capable of being switched off by a driver-controlled switch which is located forward of a vertical transverse plane passing through the R points of the front seats. The driver controlled switch is not required if a rear window, roof panel or partition is equipped with an auto-reversing device. If, however, the driver-controlled switch is present, it shall not be able to override the auto-reversing device.
- The driver-controlled switch shall be located so as to minimise any accidental manipulating. It shall be identified by the symbol shown in Appendix 4.
- 5.8.5. *Protection devices*
- All protection devices which are used to prevent damage to the power source in the case of an overload or stalling shall be capable of resetting automatically while the switch controlling the window/roof panel/partition is activated.
- 5.8.6. *Handbook instructions*
- 5.8.6.1. The owner's manual of the vehicle shall contain clear instructions relating to the power-operated window/roof panel/partition, including:
- 5.8.6.1.1. explanation of possible consequences (entrapment),
- 5.8.6.1.2. use of the driver-controlled switch,
- 5.8.6.1.3. a 'WARNING' message indicating the dangers, particularly to children in the case of improper use/activation of the power-operated windows/roof-panel systems/partition systems. This information should indicate the responsibilities of the driver, including instructions for other occupants and the recommendation to leave the vehicle only if the key is removed from the ignition lock,
- 5.8.6.1.4. a 'WARNING' message indicating that special care should be taken when using remote closing systems (see Item 5.8.2.7), for example to actuate it only when the operator has a clear view of the vehicle to be sure that nobody can be trapped by power-operated windows/roof-panel/partition equipment

▼M1 ►M2 5.9. ◀ **Other non-specified fittings**

▼B ►M2 5.9.1. ◀ The requirements of paragraph 5 shall apply to such fittings not mentioned in previous paragraphs which, within the meaning of the various requirements in points 5.1 to 5.7 and according to their location in the vehicle, are capable of being contacted by the occupants. If such parts are made of a material softer than 50 shore A hardness and mounted on (a) rigid support(s), the requirements in question shall apply only to the rigid support(s).

- ▼M2
6. GRANTING OF EC TYPE-APPROVAL OF A VEHICLE TYPE
    - 6.1. If the relevant requirements are satisfied, EC type-approval shall be granted pursuant to Article 4(3) of Directive 70/156/EEC.
    - 6.2. A model for the EC type-approval certificate is given in Appendix 2.
    - 6.3. An approval number in accordance with Annex VII to Directive 70/156/EEC shall be assigned to each type of vehicle approved. The same Member State shall not assign the same number to another type of vehicle.
  7. MODIFICATIONS OF THE TYPE AND AMENDMENTS TO APPROVALS
    - 7.1. In the case of modifications of the type approved pursuant to this Directive, the provisions of Article 5 of Directive 70/156/EEC shall apply.
  8. CONFORMITY OF PRODUCTION
    - 8.1. Measures to ensure the conformity of production shall be taken in accordance with the provisions laid down in Article 10 to Directive 70/156/EEC.

▼B  
(9.)

## INFORMATION DOCUMENT No ...

Pursuant to Annex I of Council Directive 70/156/EEC <sup>(1)</sup> relating to EC-type-approval of a vehicle with respect to the interior fittings

(Directive 74/60/EEC, as last amended by Directive 2000/4/EC)

The following information, if applicable, must be supplied in triplicate and include a list of contents. Any drawings must be supplied in appropriate scale and in sufficient detail on size A4 or on a folder of A4 format. Photographs, if any, must show sufficient detail. If the systems, components or separate technical units have electronic controls, information concerning their performance must be supplied.

- 0. GENERAL
  - 0.1. Make (trade name of manufacturer): .....
  - 0.2. Type: .....
  - 0.3. Means of identification of type, if marked on the vehicle (b): .....
  - 0.3.1. Location of that marking: .....
  - 0.4. Category of vehicle (c): .....
  - 0.5. Name and address of manufacturer: .....
  - 0.8. Address(es) of assembly plant(s): .....
- 9. BODYWORK
  - 9.10. Interior fittings
    - 9.10.1. Interior protection for occupants
      - 9.10.1.1. Layout drawing or photographs showing the position of the attached sections or views: .....
      - 9.10.1.2. Photographs or drawing showing the reference line including the exempted area (Annex I, Item 2.3.1 to Directive 74/60/EEC): .....
      - 9.10.1.3. Photographs, drawings and/or an exploded view of the interior fittings, showing the parts in the passenger compartment and the materials used, (with the exception of interior rear-view mirrors,) arrangement of controls, roof and opening roof, backrest, seats and the rear part of seats: .....
    - 9.10.3. Seats
      - 9.10.3.5. Coordinates or drawing of the R point <sup>(\*)</sup>
        - 9.10.3.5.1. Driver's seat: .....
        - 9.10.3.5.2. All other seating positions: .....
      - 9.10.3.6. Design seat back angle
        - 9.10.3.6.1. Driver's seat: .....
        - 9.10.3.6.2. All other seating positions: .....

.....  
(Date, file)

<sup>(1)</sup> The item numbers and footnotes used in this information document correspond to those set out in Annex I to Directive 70/156/EEC. Items not relevant for the purpose of this document are omitted.

▼M2

## Appendix 2

## MODEL

(maximum format: A4 (210 mm × 297 mm))

## EC TYPE-APPROVAL CERTIFICATE

STAMP OF ADMINISTRATION
----------------------------

Communication concerning the

- type-approval <sup>(1)</sup>,
- extension of type-approval <sup>(1)</sup>,
- refusal of type-approval <sup>(1)</sup>,
- withdrawal of type-approval <sup>(1)</sup>,

of a type of a vehicle/component/separate technical unit <sup>(1)</sup> with regard to Directive 74/60/EEC, as last amended by Directive 2000/4/EC

Type-approval number: .....

Reason for extension: .....

## Section I

- 0.1. Make (trade name of manufacturer): .....
- 0.2. Type: .....
- 0.3. Means of identification of type if marked on the vehicle/component/separate technical unit <sup>(1)</sup> <sup>(2)</sup>: .....
- 0.3.1. Location of that marking: .....
- 0.4. Category of vehicle <sup>(3)</sup>: .....
- 0.5. Name and address of manufacturer: .....
- 0.7. In the case of components and separate technical units, location and method of affixing of the EC approval mark: .....
- 0.8. Address(es) of assembly plant(s): .....

## Section II

1. Additional information (where applicable): see addendum
2. Technical service responsible for carrying out the tests: .....
3. Date of test report: .....
4. Number of test report: .....
5. Remarks (if any): see addendum
6. Place: .....
7. Date: .....
8. Signature: .....
9. The index to the information package lodged with the approval authority, which may be obtained on request, is attached.

Addendum to EC type-approval certificate No ... concerning the type-approval of a vehicle with regard to Directive 74/60/EEC, as last amended by Directive 2000/4/EC

1. Additional information
  - 1.1. Type of bodywork: .....
  - 1.2. Number of seats: .....
5. Remarks: .....  
(e.g. valid for both left-hand drive and right-hand drive vehicles)

<sup>(1)</sup> Delete where not applicable.<sup>(2)</sup> If the means of identification of type contains characters not relevant to describe the vehicle, component or separate technical unit covered by this type-approval certificate such characters shall be represented in the documentation by the symbol: "?" (e.g. ABC??123??).<sup>(3)</sup> As defined in Annex II, Section A to Directive 70/156/EEC.

▼M2

Appendix 3

POSITION OF CYLINDRICAL TEST ROD IN THE OPENING ROOF AND WINDOW OPENINGS

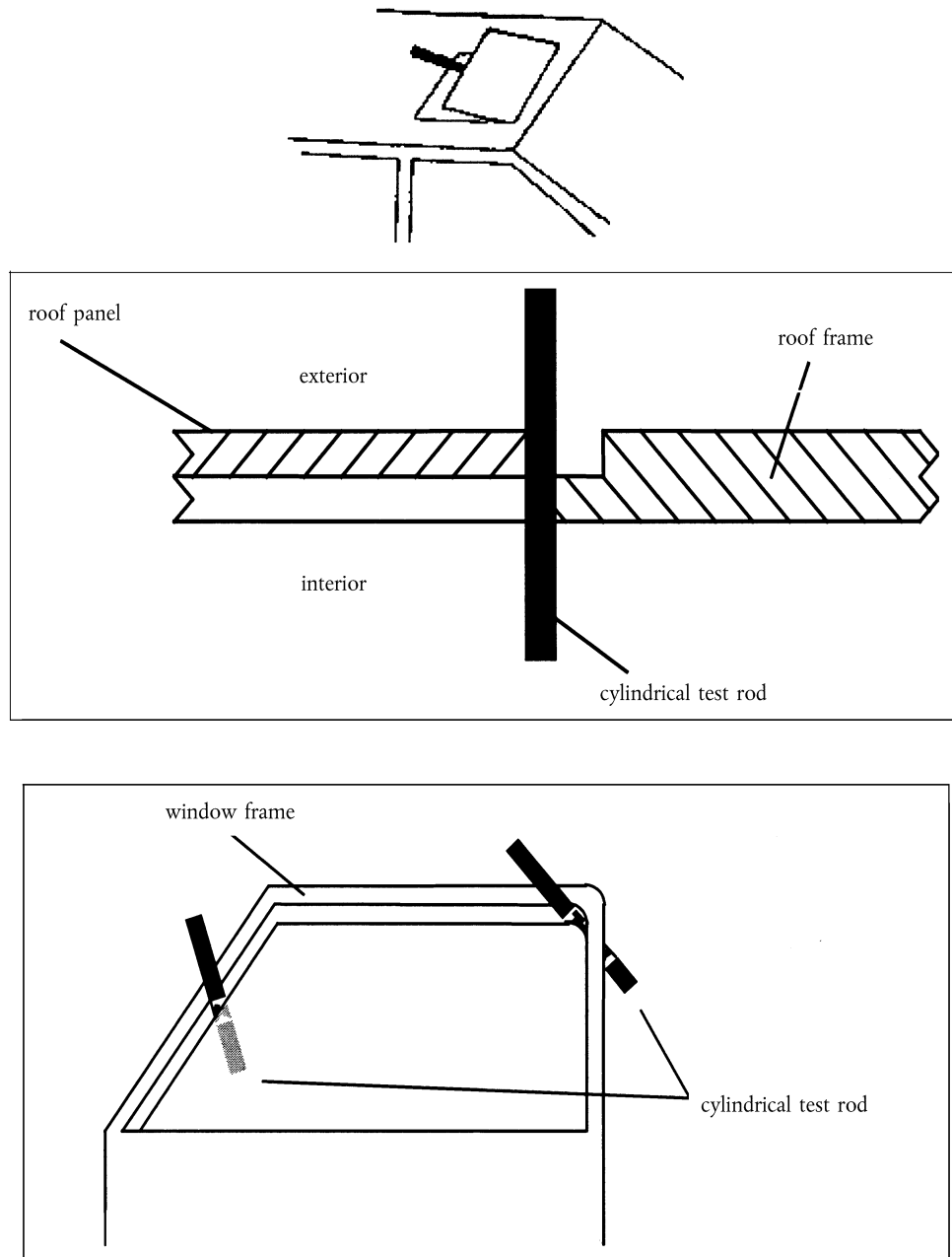

Figure 1

—

▼M2

*Appendix 4*

**SYMBOL FOR DRIVER CONTROLLED SWITCH**

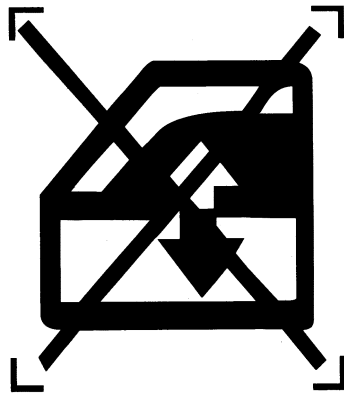



ANNEX II

**DETERMINATION OF THE HEAD-IMPACT ZONE**

1. The head-impact zone shall comprise all the non-glazed surfaces of the interior of a vehicle which are capable of entering into static contact with a spherical head 165 mm in diameter which is an integral part of a measuring apparatus whose dimensions from the pivotal point of the hip to the top of the head is continuously adjustable between 736 mm and 840 mm.
2. The aforesaid zone must be determined by the following procedure or its graphic equivalent:
  - 2.1. The pivotal point of the measuring apparatus shall be placed as follows for each seating position for which the manufacturer has made provision:
    - 2.1.1. in the case of sliding seats
      - 2.1.1.1. at the H point (see Annex IV) and
      - 2.1.1.2. at a point situated horizontally 127 mm forward of the H point and at a height either resulting from the variation in the height of the H point caused by a forward shift of 127 mm or of 19 mm.
    - 2.1.2. in the case of non-sliding seats, at the H point of the seat under consideration.
  - 2.2. ►**M1** All points of contact situated forward of the H point shall be determined for each dimension from the pivotal point to the top of the head capable of being measured by the measuring apparatus within the interior dimensions of the vehicle.  
 In the case where the headform, with the arm set at minimum length, overlaps the front seat, from the rear H point, no contact point is established for this particular operation. ◀
  - 2.3. ►**M1** With the measuring apparatus vertical, possible points of contact shall be determined by pivoting it forwards and downwards through all arcs of vertical planes as far as 90° on either side of the longitudinal vertical plane of the vehicle which passes through the H point. ◀
3. A 'point of contact' shall be a point at which the head of the apparatus contacts a part of the interior of the vehicle. The maximum downward movement shall be limited to a position where the head is tangential to a horizontal plane situated 25.4 mm above the H point.

**▼B**

## ANNEX III

**PROCEDURE FOR TESTING ENERGY DISSIPATING MATERIALS**

## 1. SETTING UP, TEST APPARATUS AND PROCEDURE

1.1. **Setting up**

1.1.1. The energy-dissipating material shall be mounted and tested on the structural supporting member on which it is to be installed on the vehicle. The test shall preferably be carried out, where possible, directly on the body. The structural member, or the body, shall be firmly attached to the test bench so that it does not move under impact.

1.1.2. However, at the manufacturer's request, the item may be mounted on a fitting simulating its installation on the vehicle, on condition that the 'component/fitting' assembly has the same geometrical arrangement and a degree of rigidity not lower and on energydissipating capacity not higher than those of the real 'component/structural supporting member' assembly.

1.2. **Test apparatus**

1.2.1. This apparatus shall consist of a pendulum whose pivot is supported by ballbearings and whose reduced mass<sup>(1)</sup> at its centre of percussion is 6.8 kg. The lower extremity of the pendulum shall consist of a rigid headform 165 mm in diameter whose centre is identical with the centre of percussion of the pendulum.

1.2.2. The headform shall be fitted with 2 decelerometers and a speed measuring device, all capable of measuring values in the direction of impact.

1.3. **Recording instruments**

The recording instruments used shall be such that measurements can be made with the following degrees of accuracy:

## 1.3.1. Acceleration:

- accuracy = ± 5 % of the real value
- frequency response = up to 1 000 Hz
- cross axis sensitivity = < 5 % of the lowest point on the scale

## 1.3.2. Speed:

- accuracy = ± 2.5 % of the real value
- sensitivity = 0.5 km/h

**▼M1**

(1.3.3.)

**▼B**

## 1.3.4. Time recording:

- the instrumentation shall enable the action to be recorded throughout its duration and readings to be made to within one thousandth of a second
- the beginning of the impact at the moment of first contact between the headform and the test component shall be noted on the recordings used for analysing the test.

<sup>(1)</sup> Note: The relationship of the reduced mass 'm<sub>r</sub>' of the pendulum to the total mass 'm' of the pendulum at a distance 'a' between the centre of percussion and the axis of rotation and at a distance 'l' between the centre of gravity and the axis of rotation is given by the formula:

$$m_r = m \frac{l}{a}$$

**▼B****1.4. Test procedure**

- 1.4.1. ►**M1** At every point of impact on the surface to be tested, the direction of impact shall be the tangent to the trajectory of the headform of the measuring apparatus described in Annex II.

For the testing of the parts as referred to in points 5.3.4.1 and 5.4.2.2 of Annex I, proceed by lengthening the arm of the measuring apparatus until contact is made with the part to be considered, up to a limit of 1 000 mm between the pivot point and top of the head of the apparatus. However, any roof sticks and ribs referred to in points 5.4.2.2 which cannot be contacted remain subject to the requirements of point 5.4.2.1 of Annex I with the exception of that relating to the height of projection.



- 1.4.2. Where the angle between the direction of impact and the perpendicular to the surface at the point of impact is 5° or less, the test shall be carried out in such a way that the tangent to the trajectory of the centre of percussion of the pendulum coincides with the direction defined in point 1.4.1. The headform shall strike the test component at a speed of 24·1 km/h; this speed shall be achieved either by the mere energy of propulsion or by using an additional propelling device.
- 1.4.3. Where the angle between the direction of impact and the perpendicular to the surface at the point of impact is more than 5°, the test may be carried out in such a way that the tangent to the trajectory of the centre of percussion of the pendulum coincides with the perpendicular to the point of impact. The test speed shall then be reduced to the value of the normal component of the speed prescribed in point 1.4.2.

**2. RESULTS**

In tests carried out according to the above procedures, the deceleration of the headform shall not exceed 80 g continuously for more than 3 milliseconds. The deceleration rate taken shall be the average of the readings of the two decelerometers.

**3. EQUIVALENT PROCEDURES**

- 3.1. Equivalent test procedures shall be permitted, on condition that the results required in paragraph 2 above can be obtained.
- 3.2. Responsibility for demonstrating the equivalence of a method other than that described in paragraph 1 shall rest with the person using such a method.

▼**B**

## ANNEX IV

▼**M1**

**PROCEDURE FOR DETERMINING THE H POINT AND THE ACTUAL SEAT-BACK ANGLE AND FOR VERIFYING THE RELATIVE POSITIONS OF THE R AND H POINTS AND THE RELATIONSHIP BETWEEN THE DESIGN SEAT-BACK ANGLE AND THE ACTUAL SEAT-BACK ANGLE**

## 1. DEFINITIONS

1.1. **H point**

The 'H point', which indicates the position of a seated occupant in the passenger compartment, is the intersection, in a longitudinal vertical plane, of the theoretical axis of rotation between the thighs and torso of a human body represented by the manikin described in point 3.

1.2. **R point or seating reference point**

The 'R point' or 'seating reference point' is the reference point specified by the vehicle manufacturer which:

- 1.2.1. has coordinates determined in relation to the vehicle structure;
- 1.2.2. corresponds to the theoretical position of the point of torso/thighs rotation (H point) for the lowest and most rearward normal driving position or position of use given by the vehicle manufacturer for each seating position specified by him.

1.3. **Seat-back angle**

'Seat-back angle' means the inclination of the seat-back in relation to the vertical.

1.4. **Actual seat-back angle**

'Actual seat-back angle' means the angle formed by the vertical through the H point with the torso reference line of the human body represented by the manikin described in point 3.

1.5. **Design seat-back angle**

'Design seat-back angle' means the angle prescribed by the vehicle manufacturer which:

- 1.5.1. determines the seat-back angle for the lowest and most rearward normal driving position or position of use given by the vehicle manufacturer for each seating position specified by him;
- 1.5.2. is formed at the R point by the vertical and the torso reference line; and
- 1.5.3. corresponds theoretically to the actual seat-back angle.

## 2. DETERMINATION OF H POINTS AND ACTUAL SEAT-BACK ANGLES

2.1. An H point and an actual seat-back angle shall be determined for each seating position specified by the vehicle manufacturer. If the seating positions in the same row can be regarded as similar (bench seat, identical seats, etc.) only one H point and one actual seat-back angle shall be determined for each row of seats, the manikin described in point 3 being seated in a place regarded as representative for the row. This place shall be:

- 2.1.1. in the case of the front row, the driver's seat;
- 2.1.2. in the case of the rear row or rows, an outer seat;

2.2. When an H point and an actual seat-back angle are being determined, the seat considered shall be placed in the lowest and most rearward normal driving position or position of use given for it by the vehicle manufacturer. The seat-back shall, if its inclination is adjustable, be locked as specified by the manufacturer, or in the absence of any such

▼**MI**

specification, in a position corresponding to an actual seat-back angle of as near as possible to 25°.

## 3. DESCRIPTION OF THE MANIKIN

- 3.1. A three-dimensional manikin of a mass and contour corresponding to those of an adult male of average height shall be used. Such a manikin is depicted in Figures 1 and 2 of the Appendix to this Annex.
- 3.2. The manikin shall comprise:
  - 3.2.1. two components, one simulating the back and the other the seat of the body, pivoting on an axis representing the axis of rotation between the torso and the thigh. The intersection of this axis with the vertical medium longitudinal plane of the seating position determines the H point;
  - 3.2.2. two components simulating the legs and pivotally attached to the component simulating the seat; and
  - 3.2.3. two components simulating the feet and connected to the legs by pivotal joints simulating ankles.
- 3.2.4. In addition, the component simulating the seat of the body shall be provided with a level enabling its transverse orientation to be verified.
- 3.3. Body-segment weights shall be attached at appropriate points corresponding to the relevant centres of gravity, so as to bring the total mass of the manikin up to  $75 \text{ kg} \pm 1 \%$ . Details of the mass of the various weights are given in the table in Figure 2 of the Appendix to this Annex.
- 3.4. The torso reference line of the manikin is represented by a straight line passing through the joint between the thigh and the torso and the theoretical joint between the neck and the thorax (see Figure 1 of the Appendix to this Annex).

## 4. SETTING UP THE MANIKIN

The three-dimensional manikin shall be set up in the following manner:

- 4.1. the vehicle shall be placed on a horizontal plane and the seats adjusted as prescribed in point 2.2;
- 4.2. the seat to be tested shall be covered with a piece of cloth to facilitate the correct setting-up of the manikin;
- 4.3. the manikin shall be placed on the seat concerned, its pivotal axis being perpendicular to the median longitudinal plane of the vehicle;
- 4.4. the feet of the manikin shall be placed as follows:
  - 4.4.1. in the front seats, in such a way that the level verifying the transverse orientation of the seat of the manikin is brought to the horizontal;
  - 4.4.2. in the rear seats, as far as possible in such a way as to be in contact with the front seats. If the feet then rest on parts of the floor which are at different levels, the foot which first comes into contact with the front seat shall serve as a reference point and the other foot shall be so arranged that the level enabling the transverse orientation of the seat of the manikin to be verified is brought to the horizontal;
  - 4.4.3. if the H point is being determined at a centre seat, the feet shall be placed one on each side of the tunnel;
- 4.5. the weights shall be placed on the legs, the level verifying the transverse orientation of the seat of the manikin shall be brought to the horizontal, and the thigh weights shall be placed on the component representing the seat of the manikin;
- 4.6. the manikin shall be moved away from the seat-back by means of the knee-pivot bar and the back of the manikin shall be pivoted forwards. The manikin shall be repositioned on the seat of the vehicle by being slid backwards on its seat until resistance is encountered, the back of the manikin then being replaced against the seat-back;
- 4.7. a horizontal load of  $10 \pm 1 \text{ daN}$  shall be applied to the manikin twice. The direction and point of application of the load are shown by a black arrow in Figure 2 of the Appendix;
- 4.8. the seat weights shall be installed on the right and left sides, and the torso weights shall then be placed in position. The transverse level of the manikin shall be kept horizontal;

**▼MI**

- 4.9. the transverse level of the manikin being kept horizontal, the back of the manikin shall be pivoted forwards until the torso weights are above the H point, so as to eliminate any friction with the seat-back;
  - 4.10. the back of the manikin shall be gently moved rearwards so as to complete the setting-up operation. The transverse level of the manikin shall be horizontal. If it is not, the procedure described above shall be repeated.
5. RESULTS
- 5.1. When the manikin has been set up as described in point 4, the H point and the actual seat-back angle of the vehicle seat considered are constituted by the H point and the angle of inclination of the manikin's torso reference line.
  - 5.2. The coordinates of the H point in relation to three mutually perpendicular planes, and the actual seat-back angle, shall be measured for comparison with the data supplied by the vehicle manufacturer.
6. VERIFYING THE RELATIVE POSITIONS OF THE R AND H POINTS AND THE RELATIONSHIP BETWEEN THE DESIGN SEAT-BACK ANGLE AND THE ACTUAL SEAT-BACK ANGLE
- 6.1. The results of the measurements carried out in accordance with point 5.2 for the H point and the actual seat-back angle shall be compared with the coordinates of the R point and the design seat-back angle as given by the vehicle manufacturer.
  - 6.2. The relative positions of the R point and the H point and the relationship between the design seat-back angle and the actual seat-back angle shall be considered to be satisfactory for the seating position in question if the H point, as defined by its coordinates, lies within a longitudinal rectangle whose horizontal and vertical sides are 30 and 20 mm long respectively and whose diagonals intersect at the R point, and if the actual seat back angle is within 3° of the design seat-back angle.
    - 6.2.1. If these conditions are met, the R point and the design seat-back angle shall be used for the test and, if necessary, the manikin shall be so adjusted that the H point coincides with the R point and the actual seat-back angle coincides with the design seat-back angle.
  - 6.3. If the H point or the actual seat-back angle does not satisfy the requirements of point 6.2, the H point or the actual seat-back angle shall be determined twice more (three times in all). If the results of two of these three operations satisfy the requirements, the result of the test shall be considered to be satisfactory.
  - 6.4. If at least two of the three test results do not satisfy the requirements of point 6.2, the result of these shall be considered to be not satisfactory.
  - 6.5. If the situation described in point 6.4 arises, or if verification is not possible because the vehicle manufacturer has failed to supply information regarding the position of the R point or regarding the design seat-back angle, the average of the results of the three tests may be used and be regarded as applicable in all cases where the R point or the design seat-back angle is referred to in this Directive.
  - 6.6. For verifying the relative positions of the R point and the H point and the relationship between the design seat-back angle and the actual seat-back angle in a series-produced vehicle, the rectangle referred to in point 6.2 shall be replaced by a square of 50 mm side and the actual seat-back angle shall not differ by more than 5° from the design seat-back angle.

COMPONENTS OF THREE-DIMENSIONAL MANIKIN

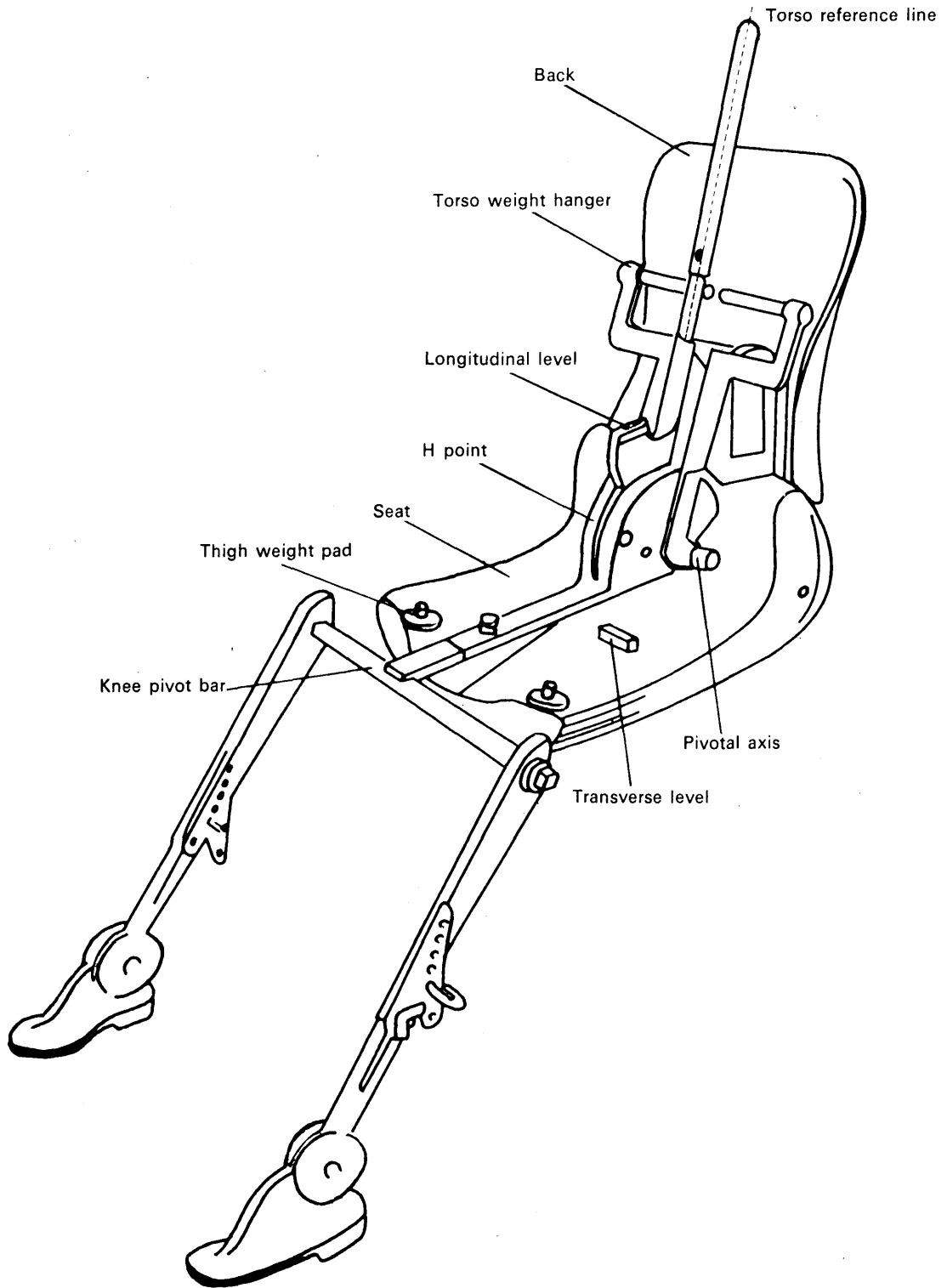

Figure 1

▼MI

DIMENSIONS AND MASS OF MANIKIN

<i>Mass of manikin</i>	<i>kg</i>
Components simulating back and seat of body	16
Mass of torso weights	31
Mass of seat weights	8
Mass of thigh weights	7
Mass of leg weights	13
Total:	75

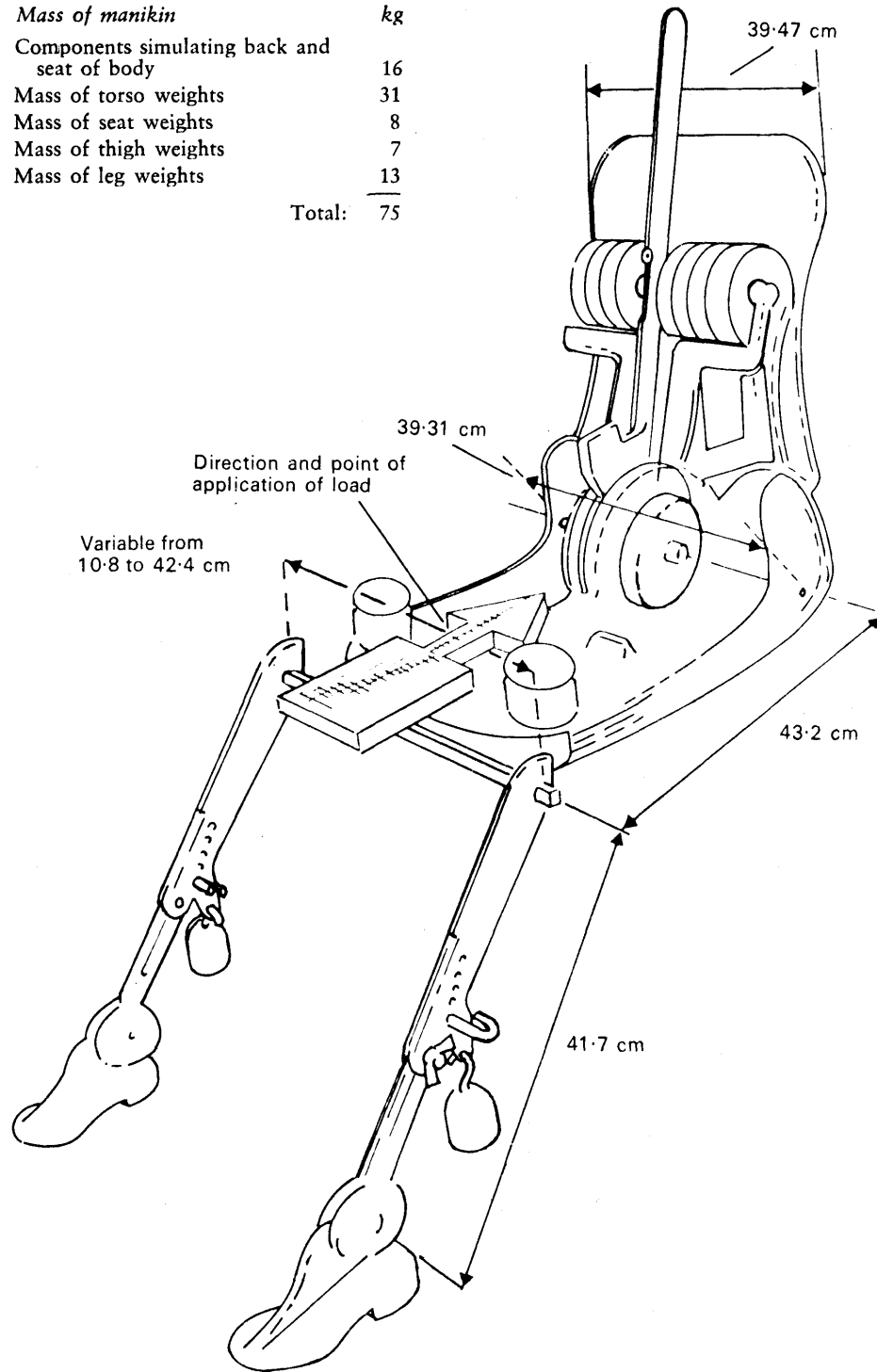

Figure 2



## ANNEX V

## METHOD OF MEASURING PROJECTIONS

1. **►M1** To determine the amount by which an item projects in relation to the panel on which it is mounted, a 165 mm sphere shall be moved along and be kept in contact with the component under consideration, starting from the initial position of contact with the component under consideration. The projection's value is the largest of all possible variations 'y', the variation measured from the centre of the sphere perpendicular to the panel.

If the panels and components, etc., are covered with materials softer than 50 Shore A hardness, the procedure for the measuring of projections described above shall apply only after the removal of such materials. ◀

2. The projection of switches, pull-knobs, etc., situated in the reference area shall be measured by using the test apparatus and procedure described below:

- 2.1. **Apparatus**

- 2.1.1. The measuring apparatus for projections shall consist of a hemispherical headform 165 mm in diameter, in which there is a sliding ram of 50 mm diameter.

- 2.1.2. Relative positions of the flat end of the ram and the edge of the headform shall be shown on a graduated scale, on which a mobile index shall register the maximum measurement achieved when the apparatus is moved away from the item tested. A minimum distance of 30 mm shall be measurable; the measuring scale shall be graduated in half-millimeters to make possible an indication of the extent of the projections in question.

- 2.1.3. *Gauging procedure:*

- 2.1.3.1. The apparatus shall be placed on a flat surface so that its axis is perpendicular to that surface. When the flat end of the ram contacts the surface, the scale shall be set at zero.

- 2.1.3.2. A 10 mm strut shall be inserted between the flat end of the ram and the retaining surface; a check shall be made to ensure that the mobile index records this measurement.

- 2.1.4. The apparatus for measuring projections is illustrated in figure 1.

- 2.2. **Test procedure**

- 2.2.1. A cavity shall be formed in the headform by pulling back the ram and the mobile index shall be placed against the ram.

- 2.2.2. The apparatus shall be applied to the projection to be measured so that the headform contacts the maximum surrounding surface area, with a force not exceeding 2 daN.

- 2.2.3. The ram shall be pushed forward until it makes contact with the projection to be measured and the amount of the projection shall be observed on the scale.

- 2.2.4. The headform shall be adjusted to obtain maximum projection. The amount of the projection shall be recorded.

- 2.2.5. If two or more controls are situated sufficiently close for the ram or the headform to contact them simultaneously, they shall be treated as follows:

- 2.2.5.1. Multiple controls, all of which can be contained in the headform cavity, shall be regarded as forming a single projection.

- 2.2.5.2. If other controls prevent normal testing by contacting the headform, they shall be removed and the test shall be conducted without them. They may subsequently be re-installed and tested in their turn with other controls that have been removed to facilitate the procedure.

Appendix

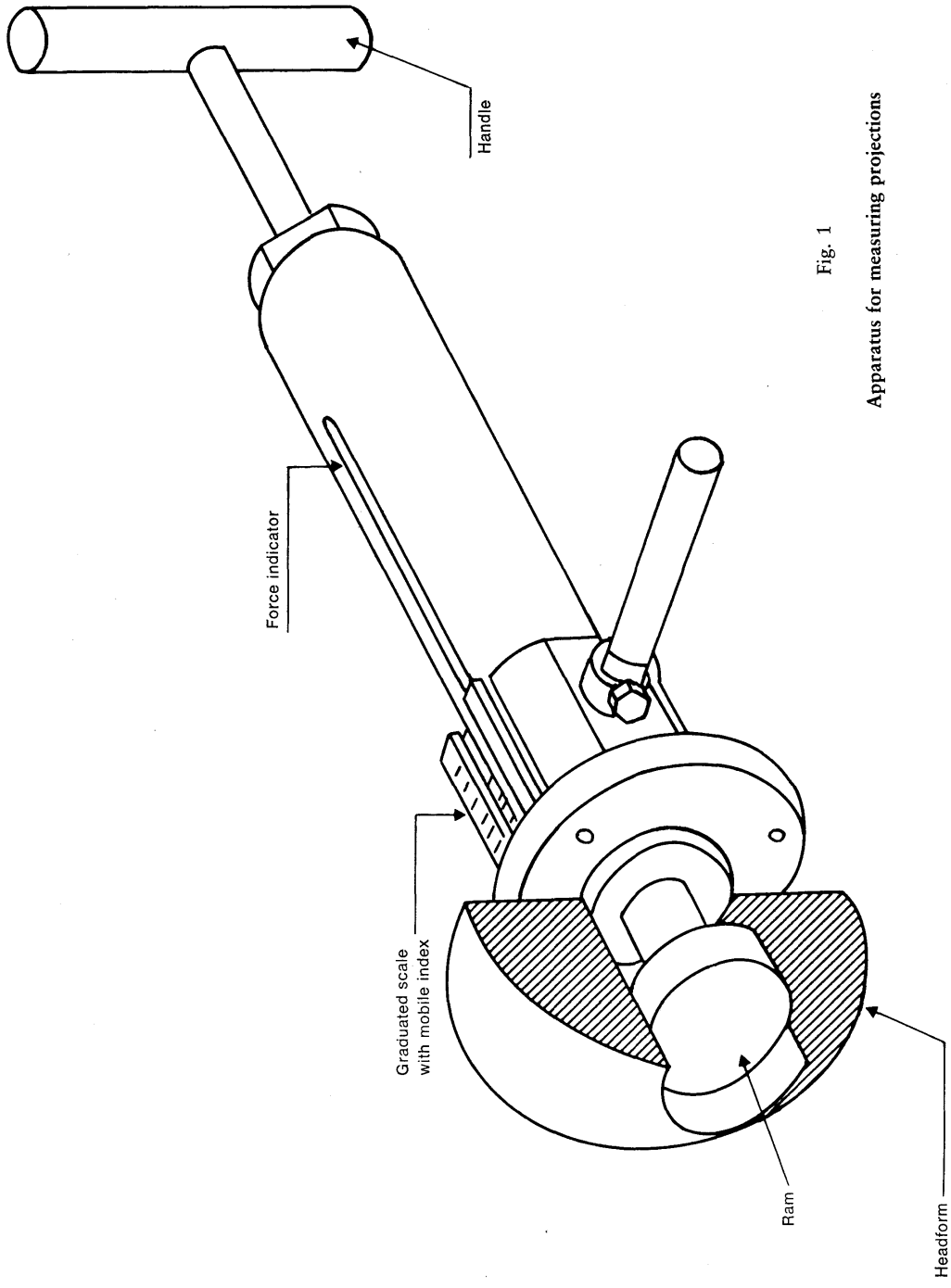

Fig. 1

Apparatus for measuring projections

▼**B**

## ANNEX VI

**APPARATUS AND PROCEDURE FOR APPLICATION OF ITEM 5.2.1 OF ANNEX I**

Those parts (switches, pull-knobs etc.) which can be contacted by using the apparatus and procedure described below shall be considered as being likely to be contacted by the knees of an occupant:

**1. Apparatus**

Diagram of apparatus

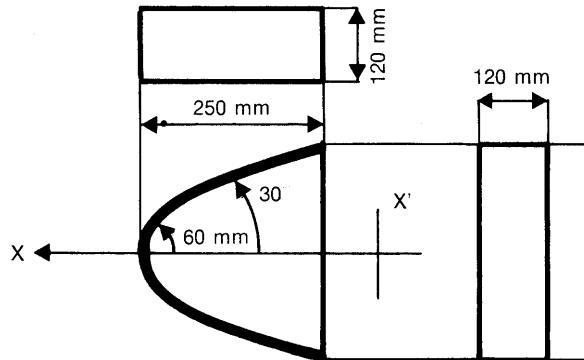
**2. Procedure**

The apparatus may be placed in any position ► **C2** below the level of the instrument panel ◀ so that:

- the plane  $XX'$  remains parallel to the median longitudinal plane of the vehicle
- the axis  $X$  can be rotated above and below the horizontal through angles up to  $30^\circ$ .

3. In carrying out the above test, all materials of less than 50 shore A hardness shall be removed.



APPENDIX TO ANNEXES I, II, III, IV AND VI

NOTES

TO ANNEX I

**DEFINITIONS, APPLICATIONS FOR EEC-TYPE APPROVAL AND SPECIFICATIONS**

To point 2.2:

The reference zone is outlined without rear view mirror. The energy-dissipation test is accomplished without the rear view mirror. The pendulum shall not impact the mirror mounting.

To points 2.3 and 2.3.1:

The exemption defined by these points behind the steering wheel is also valid for the head impact area of the front passenger(s).

In the case of adjustable steering wheels the zone finally exempted is reduced to the common area of the exempted zones for each of the driving positions which the steering wheel may assume.

In the case where it is possible to choose between various steering wheels the exempted zone is determined by the use of the least favourable steering wheel having the smallest diameter.

To point 2.4:

The level of the instrument panel extends over the entire width of the passenger compartment and is defined by the rearmost points of contact of a vertical line with the surface of the instrument panel when the line is moved across the width of the vehicle. Where two or more points of contact occur simultaneously then the lower point of contact shall be used to establish the level of the instrument panel. In the case of consoles, if it is not possible to determine the level of the instrument panel by reference to the points of contact of a vertical line then the level of the instrument panel shall be where a horizontal line 25.4 mm above the H point of the front seats intersects the console.

To point 2.5:

At the vehicle sides the roof shall commence at the upper edge of the door aperture. In the normal case the lateral roof limits will be represented by the contours formed by the bottom edge (lateral view) of the remaining body when the door has been opened. In the case of windows the lateral limitation of the roof will be the continuous transparent line (penetration point of the lateral window panes). At the posts the lateral roof limitation will pass through the connecting line between the transparent lines. The definition of point 2.5 is also valid for any opening for the roof, in the closed position, of a vehicle as defined in point 2.7 or 2.8.

For measuring purposes downward facing flanges shall be ignored. These will be considered as forming part of the vehicle sidewall.

▼M1

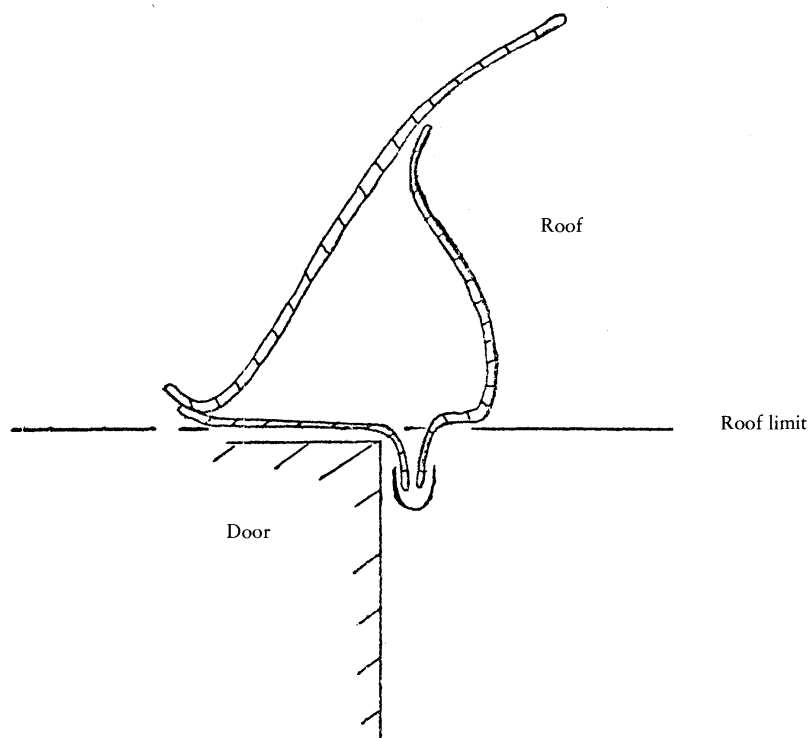

To point 2.7:

A non-removable rear window is understood to be a rigid structural element.

Cars with non-removable rear windows of rigid material are considered to be cars with opening roofs as defined under point 2.8.

To point 5.1.1:

A sharp edge is an edge of a rigid material having a radius of curvature of less than 2.5 mm except in the case of projections of less than 3.2 mm, measured from the panel. In this case the minimum radius of curvature shall not apply provided the height of the projection is not more than half its width and its edges are blunted.

Grills are considered to comply with the regulations if they meet the minimum requirements of the following table:

(in mm)

Gap between elements	Flat elements		Rounded elements (min. radius)
	e/min.	radius min.	
0 to 10	1.5	0.25	0.50
10 to 15	2.0	0.33	0.75
15 to 20	3.0	0.50	1.25

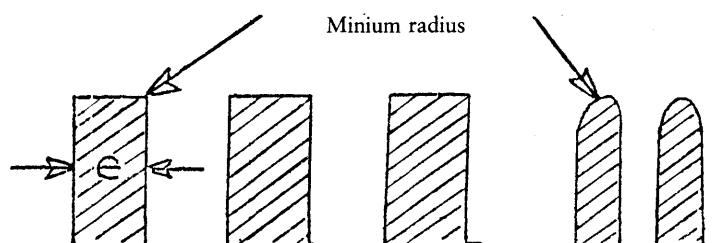

## ▼MI

To point 5.1.2:

During the test it is determined whether parts within the impact zone used for reinforcement may be displaced or protrude so as to increase the hazards to passengers or the severity of injuries.

To point 5.1.3:

These two concepts (level and lower edge of the instrument panel) may be distinct. However, this paragraph is included in point 5.1 (... above the level of the instrument panel...) and, therefore, is applicable only where these two concepts are combined. In the case where the two concepts are not combined, i.e. where the bottom edge of the instrument panel is located below the level of the instrument panel, it will be considered under point 5.3.2.1 by reference to point 5.8.

To point 5.1.4:

If a pull handle or knob has a width dimension equal to or more than 50 mm and is located in a zone such that if it were less than 50 mm in width the maximum projection would be determined using the headform measuring apparatus with point 2 of Annex V, the maximum projection shall be determined in accordance with point 1 of Annex V, i.e. by using a 165 mm diameter sphere and determining the maximum variation in height of the 'y' axis.

The cross-sectional area shall be measured in a plane parallel to the surface on which the component is mounted.

To point 5.1.5:

Points 5.1.4 and 5.1.5 complement each other; the first sentence of point 5.1.5 (i.e. a force of 37.8 daN for retraction or detachment) is applied and then point 5.1.4 in case of retraction up to a protrusion between 3.2 and 9.5 mm or, in the case of detachment, the two last sentences of point 5.1.5 (the cross-section area is measured before the force is applied). However, if, under practical circumstances point 5.1.4 must be applied (retraction to under 9.5 mm and over 3.2 mm), it could be more convenient, at the manufacturer's discretion, to verify the specifications of point 5.1.4 before applying the force of 37.8 daN specified in point 5.1.5.

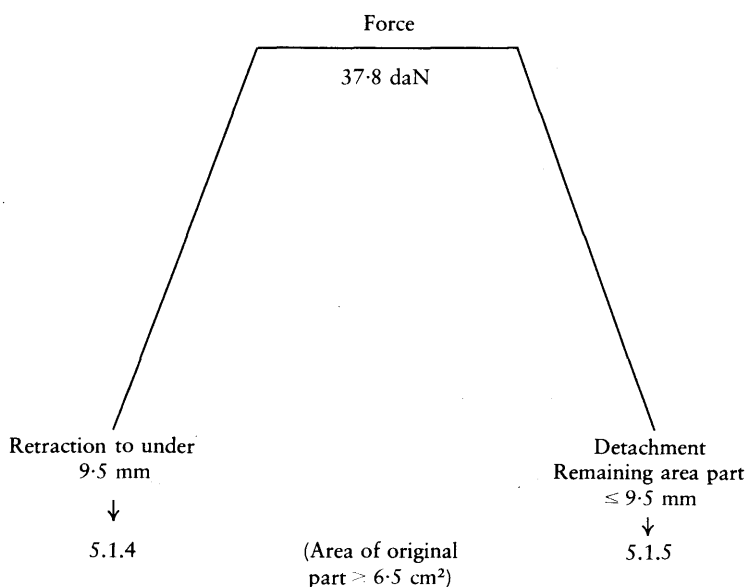

To point 5.1.6:

Since in the presence of soft materials, the requirements apply only to the rigid support, the projection is measured for the rigid support only.

The Shore hardness measurement is made on samples of the test subject itself. Where, due to the condition of the material it is impossible to carry out a hardness measurement by the Shore A procedure, comparable measurements shall be used for evaluation.

**▼MI**

To point 5.2.1:

Foot pedals, their arms and immediate pivotal mechanism but not the surrounding support metal shall be excluded from consideration.

To point 5.2.2:

The criterion to determine whether the parking brake control can be contacted is the use of:

- the simulated head specified in Annex II, if the control is located above or on the level of the instrument panel (to be tested in accordance with point 5.1 and within the impact zone);
- the knee specified in Annex VI if the control element is located below the level of the instrument panel (in this case the control lever is tested in accordance with point 5.3.2.3).

To point 5.2.3:

The technical specifications listed in point 5.2.3 apply also to shelves and those parts of consoles below the level of the instrument panel located between the front seats, provided that these are located in front of the H point. If a cavity is closed it will be treated as a glove compartment and not be subject to these specifications.

To point 5.2.3.1:

The dimensions specified refer to the surface before the addition of material of less than 50 Shore A hardness (see point 5.2.4). Energy-dissipating tests shall be conducted in the spirit of Annex III.

To point 5.2.3.2:

If a shelf becomes detached or breaks up no dangerous features must result; this applies not only to the rim but also to other edges facing into the passenger compartment as a result of the applied force.

The strongest part of the shelf shall be considered to be adjacent to a fixture. Also, 'substantially distorted' shall mean that, under the effect of the applied force, the deflection of the shelf, measured from the initial point of contact with the test cylinder, must be a fold or a deformation visible to the naked eye. Elastic deformation shall be admissible.

The length of the test cylinder shall be at least 50 mm.

To point 5.3:

'Other parts' shall include such parts as window catches, seat belt upper anchorages and other parts located in the foot space and at the door side, unless these parts have been treated previously or are exempted in the text.

To point 5.3.2:

That space between the forward bulkhead and the instrument panel which is located higher than the bottom edge of the instrument panel is not subject to the specifications of point 5.3.

To point 5.3.2.1:

The 3·2 mm radius applies to all contactable components covered by point 5.3 when considered in all positions of use.

As exceptions glove compartments shall be considered only in the closed position, seat belts will normally be considered only in the fastened position but any part which has a fixed stowage position shall also comply with the 3·2 mm radius requirement in that stowed position.

To point 5.3.2.2:

The reference surface is found by application of the device described in point 2 of Annex V with a force of 2 daN. Where this is not possible the method described in point 1 of Annex V shall be used with a force of 2 daN.

The evaluation of dangerous projections is subject to the discretion of the authority responsible for the tests.

The force of 37·8 daN is applied even if the original projection is less than 35 or 25 mm, as applicable. The projection is measured under the applied load.

**▼MI**

The horizontal, longitudinal force of 37·8 daN is normally applied by means of a flat-ended ram of not more than 50 mm diameter, but where this is not possible an equivalent method may be used; for instance, by removing obstacles.

To point 5.3.2.3:

The furthest projecting part in the case of a gear lever is that part of the grip or knob first contacted by a vertical transverse plane moved in a longitudinal, horizontal direction. If any part of a gear lever or handbrake lies above the H point level that lever will have to be considered as if the whole of it were above the H point level.

To point 5.3.4:

Where the horizontal plane(s) passing through the H point of the lowest front and rear seats do not coincide, then a vertical plane perpendicular to the vehicle's longitudinal axis shall be determined, passing through the front seat H point. The exempted zone will then be considered separately for both the front and rear passenger compartments, relative to their respective H point and up to the vertical plane defined above.

To point 5.3.4.1:

Movable sun visors shall be considered in all positions of use. The frames of sun visors shall not be regarded as rigid supports (see point 5.3.5).

To point 5.4:

When the roof is tested to measure those protrusions and parts which can be contacted by a ball having a diameter of 165 mm, the roof lining must be removed. When evaluating the specified radii the proportions and properties attributable to the materials of the roof lining shall be taken into consideration. The roof testing area shall extend in front of and above the transverse plane limited by the torso reference line of the manikin placed on the rearmost seat.

To point 5.4.2.1 (see point 5.1.1 for definition of 'sharp edges'):

The downward projection shall be measured normal to the roof in accordance with point 1 of Annex V.

The width of the projecting part shall be measured at right angles to the line of the projection. In particular the rigid roof sticks or ribs shall not project away from the inner surface of the roof more than 19 mm.

To point 5.5:

Any roof ribs on opening roofs must meet point 5.4 if they are contactable by a 165 mm diameter sphere;

To points 5.5.1.2, 5.5.1.2.1 and 5.5.1.2.2:

The opening and operating devices when in a position of rest and with the roof closed must meet all of the specified conditions.

To point 5.5.1.2.3:

The force of 37·8 daN is applied even if the original projection is 25 mm or less. The projection is measured under the applied load.

The force of 37·8 daN applied in the direction of impact defined in Annex III as the tangent to the trajectory of the headform is normally applied by means of a flat-ended ram of not more than 50 mm diameter, but where this is not possible an equivalent method may be used; for instance, by removing obstacles.

The 'position of rest' means the position of the operating device when it is in the locked position.

To point 5.6:

The rod system of convertible tops does not represent a roll-over bar.

To point 5.6.1:

The top part of the windscreen frame starts above the transparent contour of the windscreen.

**▼M1**

To point 5.7.1.1:

See point 5.1.1 for definition of sharp edge.

To point 5.7.1.2:

In defining the head impact zone of the back of the front seats any structure necessary to support the seat back shall be considered as a component of this seat back.

To point 5.7.1.2.3:

The padding of the seat frame structure shall also avoid dangerous roughness and sharp edges likely to increase the risk of serious injuries to the occupants.

*TO ANNEX II***DETERMINATION OF THE HEAD-IMPACT ZONE**

To point 2.1.1.2:

The choice between the two procedures for determining height is to be left to the manufacturer.

To point 2.2:

When determining points of contact, the length of the arm of the measuring apparatus is not changed during a particular operation. Each operation starts from the vertical position.

To point 3:

The 25·4 mm dimension means the measurement from a horizontal plane passing through the H point to the horizontal tangent to the lower profile of the headform.

*TO ANNEX III***PROCEDURE FOR TESTING ENERGY-DISSIPATING MATERIALS**

To point 1.4:

For breakage of any component during the energy-dissipation test, see the note on point 5.1.2 in Annex I.

*TO ANNEX IV*

**PROCEDURE FOR DETERMINING THE H POINT AND THE ACTUAL SEAT-BACK ANGLE AND FOR VERIFYING THE RELATIVE POSITIONS OF THE R AND H POINTS AND THE RELATIONSHIP BETWEEN THE DESIGN SEAT-BACK ANGLE AND THE ACTUAL SEAT-BACK ANGLE**

To point 4:

For determining the H point of any seat, other seats may be removed if necessary.

*TO ANNEX VI*

**APPARATUS AND PROCEDURE FOR APPLICATION OF POINT 5.2.1 OF ANNEX I**

First sentence:

Foot-operated controls are treated as foot pedals.